

REIGER

SUSPENSION

550

DAMPER MANUAL

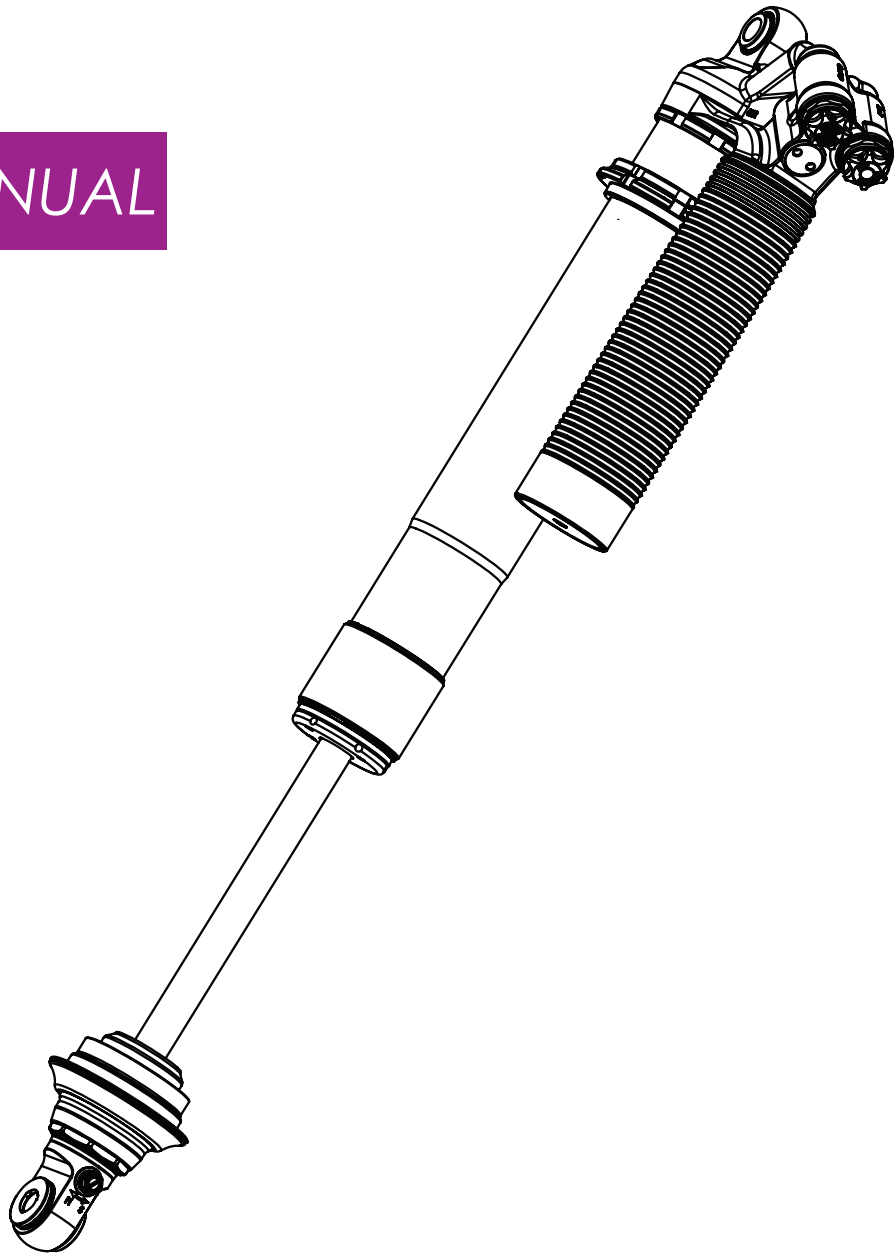

H/L SPEED - REBOUND - HDP - RCV - CCV

Reiger Suspension BV

Molenenk 5a

NL-7255 AX Hengelo Gld.

Tel.: +31 (0)575-462077

www.reigersuspension.com



GENERAL DAMPER INFORMATION



DAMPER OVERVIEW

A full option 550 damper has a high/low speed compression adjustment, HDP [Hydraulic Double Piston], CCV [Corner Control Valve], RCV [Rebound Control Valve] and a rebound adjustment (see image below).

The high speed compression adjustment is the **purple button** on the damper and the blue or green screw within this button is the low speed compression adjustment. The rebound adjustment is found at the rod end.

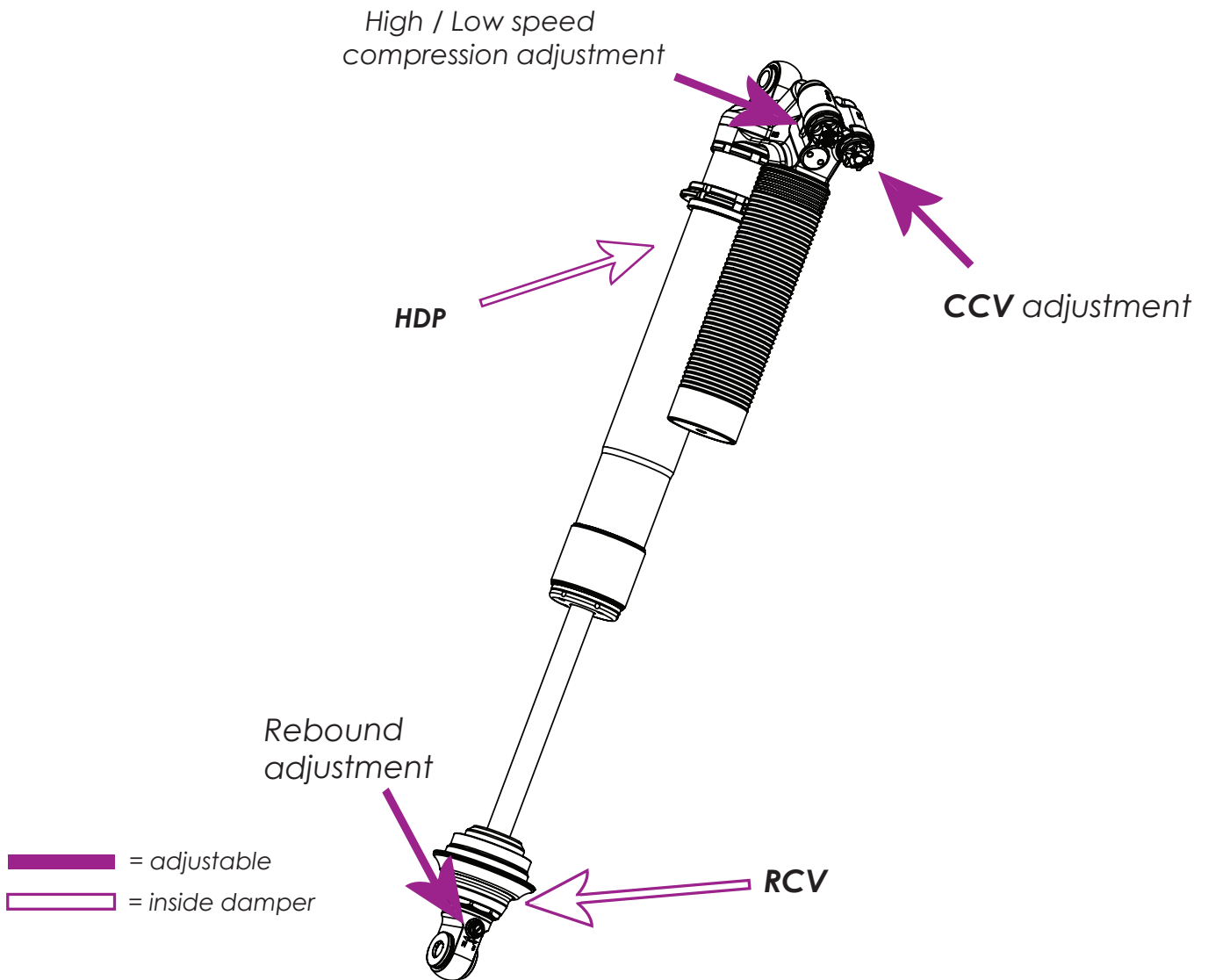

All adjustments have the same basic principle: the damper force increases when you rotate the adjustment to the right (clockwise). The maximum amount of clicks varies per adjustment. The high speed adjustment has 15 clicks, low speed 20 and the rebound adjustment has a maximum of 30 or 60 effective clicks.

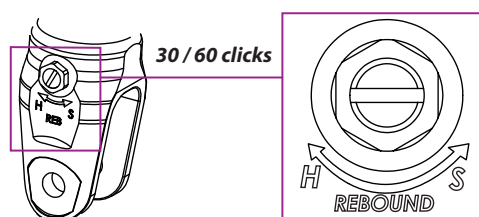

Counting clicks should always happen starting from a fully closed adjustment (= completely to the right).

Attention: never exceed the maximum amount of clicks! If you do so, you can damage the adjustment.

GENERAL DAMPER INFORMATION



HIGH / LOW SPEED COMPRESSION ADJUSTMENT

The compression damping is adjusted with the high / low speed adjustment. High speed adjustment actually is medium speed, but has been called high speed over the years.

You can adjust the slow compression speed **of the damper** with the **low speed adjustment**. This has nothing to do with the speed you drive! This adjustment with 20 clicks is the **blue or green** screw inside the purple knob and is adjustable with a small screwdriver.

Counting clicks starts from closed, which is when you rotate the adjustment all the way to the right. This is the hardest damping.

The low speed adjustment is made to stabilize your vehicle. The more this adjustment is closed, the more stable your vehicle will be. However, you will lose some traction. If you open the adjustment all 20 clicks the damper will feel softer and move better over small bumps but your vehicle will lose some stability.

The purple knob is your **high speed compression adjustment**. This adjustment has 15 clicks. Just like all adjustments all the way to the right is closed and your start for counting clicks.

Rotating this knob to the left makes the damper softer at landings after jumps. It also makes it better with stones and bumps of 10 to 25cm. Too far to the left makes your vehicle move more and so harder to handle, especially on sand tracks.

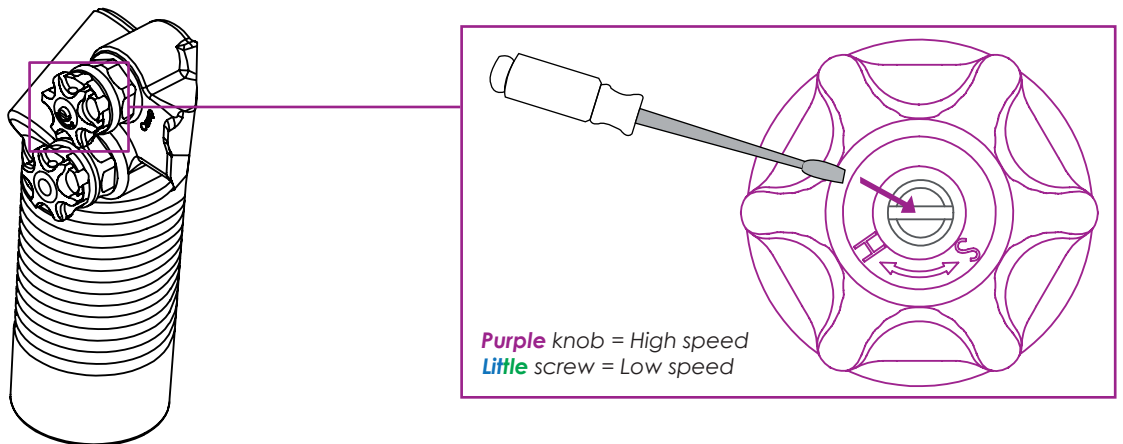

HYDRAULIC DOUBLE PISTON

HDP is designed so that the compression damping automatically adjusts to the damper speed. The compression damping increases with high impacts or hard landings for extra support, just like Double Piston. However, HDP does not have a fixed transition point (as in the case of DP), but a variable transition point that changes to suit each unique shock load.

Moreover, the change in compression damping is also dependent on damper speed, so that the harder the impact, the greater the increase in damping. Note that this adjustment only affects the last part of the damping.

GENERAL DAMPER INFORMATION



REBOUND ADJUSTMENT

The rebound damping is responsible for traction and stability. Counting starts from closed, which is when you rotate the adjustment all the way to the right.

A closed rebound adjustment means a 'slow' rebound damping: great for stability, but a little slow if you have lots of small bumps. When you open the rebound adjustment (rotate to the left) the damper gets quicker which gives more traction. However, this may give you a 'nervous' feeling.

There is a difference in driving on hard or sand tracks. We recommend to drive with 2 to 3 clicks more open on hard tracks. When driving on sand tracks you can close the rebound damping a little more.

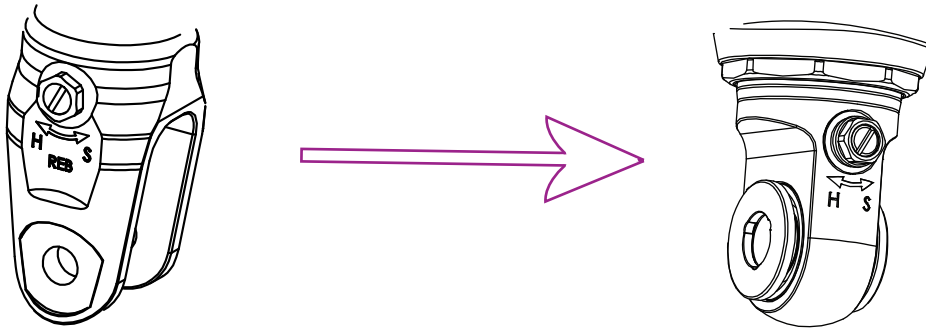

CORNER CONTROL VALVE

CCV is a system, patented by Reiger, that detects whether you drive straight or in a corner. CCV makes the compression damping of the outer dampers harder in the corner, so that there is less roll and more traction in those corners. CCV adjustment can only be applied to front dampers of a quad, for example.

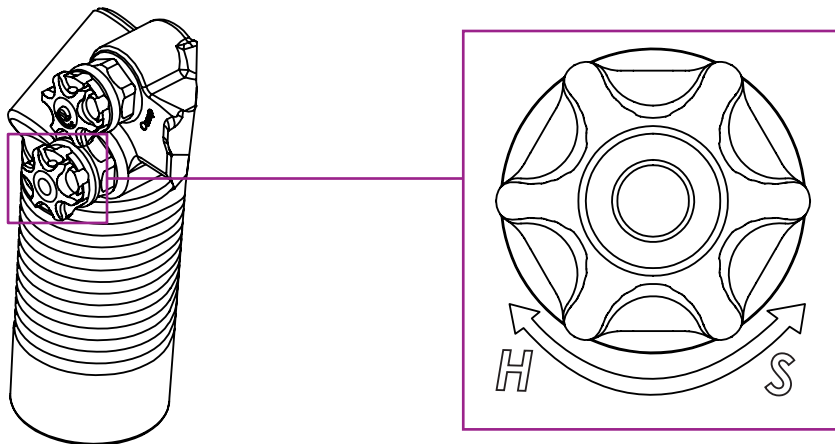

GENERAL DAMPER INFORMATION



TOOLS

The following tools are used to adjust the spring preload (free sag):



C-spanner set Ø80/85 - Ø85/90

1-19-00335 / 1-19-00333

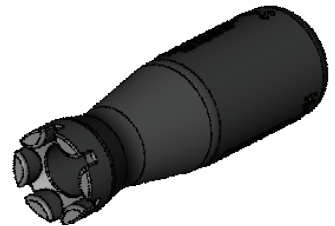

Compression adjustment tool

1-19-00421

SETUP

Reiger has special setup books to keep track of your damper setup. On these sheets you can write down different clicks (see example image). As explained, it is possible to change setup to your own preferences and different tracks or circumstances.

For example, driving in rain or in the cold might cause you to drive with different setups. With these books it is easy to retrieve which setup worked for you on which date, circuit and under which conditions.

QUESTIONS?

We are more than happy to help you with any questions. Please contact us:

Phone: +31 (0)575 - 46 20 77

E-mail. info@reigersuspension.com